

KRIFF BKL LED



Blacha aluminiowa
Malowana proszkowo
Wyposażona w moduły
LED firmy Philips
Stopień szczelności IP 65
I Klasa ochronności
Zastosowanie: tereny miejskie,
Parki, chodniki,
Ulice o małym natężeniu ruchu



Aluminum sheet
Powder coated
Equipped with modules
Philips LED
Degree of protection IP 65
I Protection class
Application: urban areas,
Parks, sidewalks,
Streets with low traffic

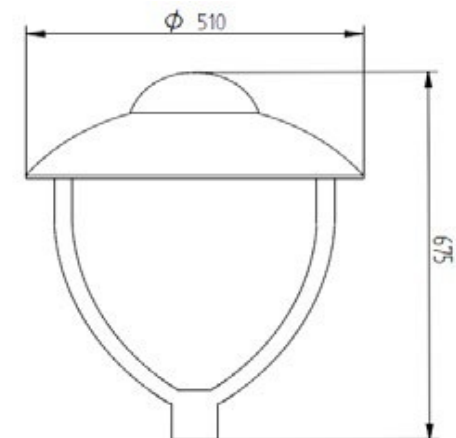

Nazwa oprawy (Luminaire name)	Moduł LED (LED module)	Moc (Wattage)	Strumień świetlny (Luminous flux)	Temperatura barwowa (Colour temperature)	Współczynnik Ra (Colour rendering index)	Czas pracy (Lifetime)
KRIFF BKL LED 2000 830	Fortimo LED DLM	25 W	2000 lm	3000 K	80	50 000 h
KRIFF BKL LED 2000 840	Fortimo LED DLM	22 W	2000 lm	4000 K	80	50 000 h
KRIFF BKL LED 3000 830	Fortimo LED DLM	37 W	3000 lm	3000 K	80	50 000 h
KRIFF BKL LED 3000 840	Fortimo LED DLM	34 W	3000 lm	4000 K	80	50 000 h
KRIFF BKL LED 5000 830	Fortimo LED DLM	49 W	5050 lm	3000 K	80	50 000 h
KRIFF BKL LED 5000 840	Fortimo LED DLM	49 W	4765 lm	4000 K	80	50 000 h